

OUTPUTS

Capacity BTU/HR @ 65°F Entering Air													
Model	Fan Speed	Pressure Drop (Ft.)	ENTERING WATER TEMPERATURE (Deg. F.) - BTU/Hrs.										
			100°	110°	120°	130°	140°	150°	160°	170°	180°	190°	200°
PSU-10	max.	2.75	1350	1850	2650	3307	4278	5325	6192	7024	7957	9081	9736
	min.		900	1120	1800	2315	2994	3727	4334	4915	5570	6350	6810
PSU-15	max.	3.07	1700	2500	3250	3983	5120	6255	7382	8933	10590	12250	14349
	min.		1100	1600	2150	2788	3580	4375	5163	6250	7412	8575	10040
PSU-23	max.	3.82	2000	3100	4700	6645	8790	10932	13070	15210	17370	19500	21530
	min.		1800	2750	3600	4650	6150	7651	9145	10645	12160	13645	15072
PSU-30	max.	4.6	2200	3400	5250	7550	10050	12750	15800	19150	22000	24900	27750
	min.		1950	2950	3800	5300	7030	8900	11020	13380	15350	17400	19425
PSU-40	max.	4.6	9000	11500	13500	16500	19720	21384	23166	25300	29402	31600	35640
	min.		7500	10000	12200	14204	17000	18250	20050	23008	25200	27055	29184

NOTES:

1. PSU 10, 15 & 23 capacities based on 2 gpm correction factors for: .5 gpm = .80; 1.5 gpm = .96; 2.5 gpm = 1.07; 3 gpm = 1.12; and 5 gpm = 1.23. PSU 30 & 40 capacities based on 3 gpm correction factors for: 1 gpm = .85; 5 gpm = 1.18.
2. Aquastat set to close on a rise to 130°F and to open on a drop to 110°F. For outputs at 130°F and below optional field mounted 110°F-90°F aquastat is required.
3. It is recommended that selections be made at low speed at the desired water temperature.

MODEL	UNIT WEIGHT	WT. PACKED	CUBIC FT./MINUTE	
			MAX.	MIN.
PSU-10	24.6 lbs.	28 lbs.	75	50
PSU-15	33 lbs.	37 lbs.	140	100
PSU-23	44 lbs.	50 lbs.	210	150
PSU-30	37.75 lbs.	45.25 lbs.	270	196
PSU-40	53.56 lbs.	62.86 lbs.	378	275

ENGINEERING SPECIFICATIONS

Construction. All PSU fan convectors are constructed of an internal "Heatpack" section mounted to a well designed back chassis. All components are then enclosed under a shroud (cover) which is made of high grade zinc coated steel painted with a dove grey baked enamel finish.

"Heatpack" Section. A uniquely designed internal component consisting of the coil, fan and motor assembly and all controls integrally mounted.

Heat Exchanger. A highly efficient, headered coil, made of copper tubes expanded into smooth aluminum plate fins (10 FPI), tested at 300 PSI, and sealed for quality. The heat exchanger is positioned in each PSU unit for maximum heat transfer over the coil.

Fan and Motor Assembly. High spec tangential SEL fan and motor assembly consists of high static fan wheel and scroll, detachable motor, replaceable "easy glide" sleeve bearings, and the fan and motor cut out are protected to UL/CSA specifications. This fan and motor assembly is designed to run whisper quiet without vibration.

Controls. All PSU units have integral two speed, max.-off-min., and switches (optional wall mounted fan speed controller is available). The LTC – low limit aquastat is also a high spec item with a close tolerance designed to close on a rise to 130°F+/-3°F and open at 110°F+/-3°F. For low temperature systems you will have to change out the aquastat located on the second copper tube U bend behind the speed switch, in the main control box, underneath the cover shroud.

Water Connections. Supply and return connections are 1/2" (PSU 10, 15 & 23) or 3/4" (PSU 30 & 40) sweat connections located on the left hand side of the unit as you face the grille. A water vent with wide convenient screwdriver slot is accessible on the left of the unit underneath.

Electrical Connections. (PSU 10, 15 & 23) 120/60/1 power supply is required. The cover shroud (i.e. the cover) must be removed to bleed the unit. (PSU 30 & 40) 120/60/1 power supply is required. All that's required is to knock out the junction box hole you want to use and wire to the L1 and L2 leads. There is a convenient one screw access plate on the top of the unit to get at the ground.



**Models
PSU 10,
PSU 15,
PSU 23,
PSU 30,
PSU 40
Fan
Convectors**

- Quiet efficient operation.
- Delivers a range from 3,000 to 40,000 BTUH in five different sizes.
- Three position fan switch for maximum control.
- Features the E-Z hanger mounting bracket.
- Attractive dove grey baked enamel finish.
- Ideal for dormitories, hotel, hospitals or any application where high BTU output is required with limited available wall space.

The Profile series fan convectors are slim, attractive surface mounted units with a base skirt which allows them to be wall mounted or floor mounted. All PSU units feature a three position max.-off-min switch with internal aquastat for individual heater control. A BTU/hr range from 3,000 BTU/hr to 40,000 BTU/hr gives a fast, efficient way to heat a room while using a minimum of wall space. A pleasing neutral light grey paint finish is ideal for many decors. This high grade finish may be used as is or may be field painted, wall papered, or marbled.

The Profile series is ideal for residential and commercial applications where high BTU output is required with limited available wall space.

Designed to deliver high BTU output where there is limited available wall space

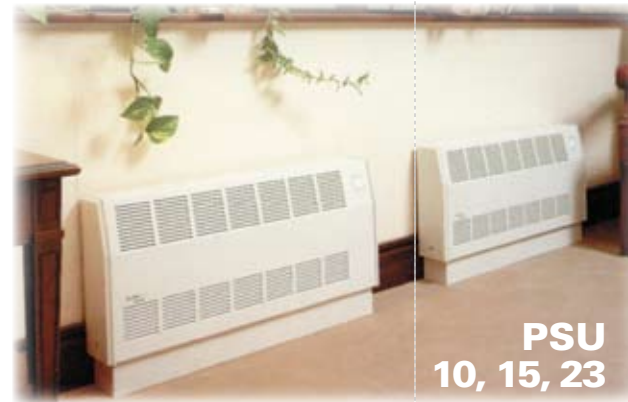

PSU
10, 15, 23

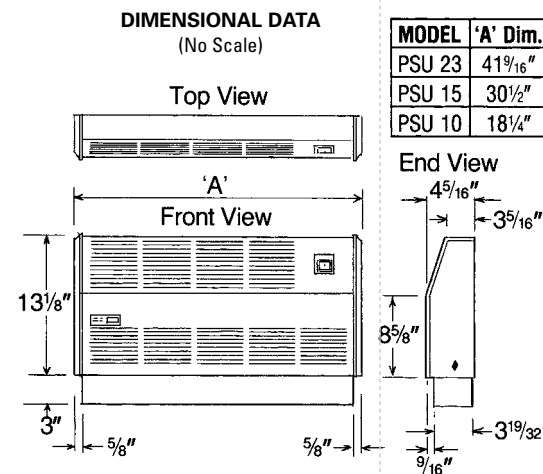

E-Z Hanger

All PSU Profile Series models include the E-Z HANGER mounting bracket to reduce installation time and enhance serviceability.

Our Larger Units

These larger units deliver up to 29,000 BTUH (PSU 30) and 40,000 BTUH (PSU 40).

PSU 40



PSU 30

